

# VITI PER PLASTICA SENZA PUNTA TIPO FX - INFORMAZIONI TECNICHE

SCREWS WITH BLUNT TIP FOR PLASTIC FX TYPE- TECHNICAL INFORMATION

SCHRAUBEN OHNE SPITZE FÜR KUNSTSTOFF FX - TECHNISCHE INFORMATIONEN

VIS À BOUT PLAT POUR PLASTIQUE FX- DONNÉES TECHNIQUES

TORNILLOS METALICOS SIN PUNTA PARA FIJAR EN PLASTICO FX- INFORMACION TECNICA

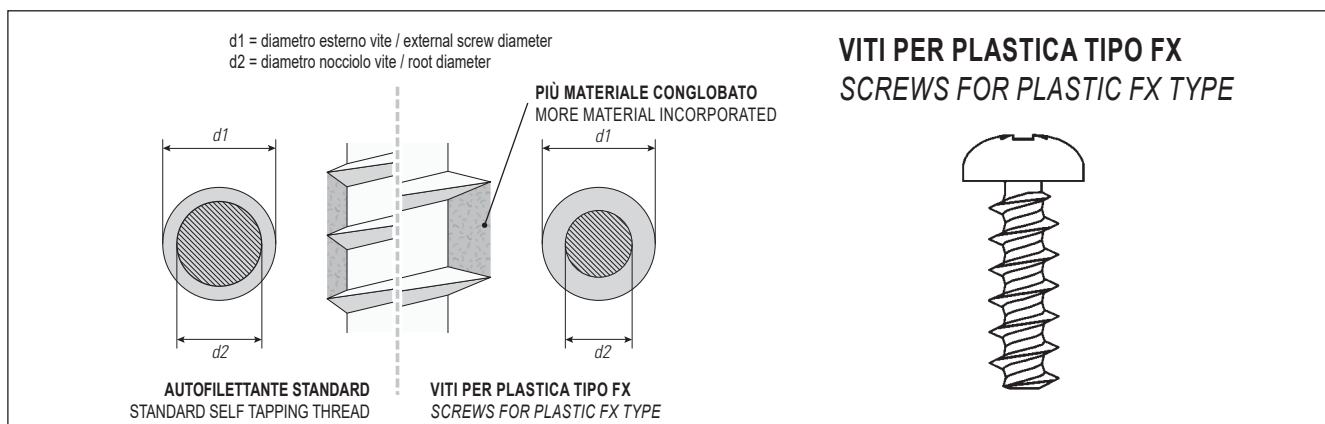

Diametro vite nominale (d1) Nominal screw diameter (d1)	2.2	2.5	3.0	3.5	4.0	4.5*	5.0	5.5*	6.0	7.0
Foro/Hole da/from d1x0,7 fino a/ from d1x0,85	1.54-1.87	1.75-2.12	2.10-2.55	2.45-2.97	2.80-3.4	3.15-3.82	3.50-4.25	3.85-4.67	4.20-5.1	4.90-5.95
Coppia di rottura minima (Nm) Breaking torque (Nm)	0.52	0.60	1.00	1.45	2.15	2.85	4.35	6.55	9.15	15.60
Coppia di chiusura (Nm) Tightening torque (Nm)	0.30	0.40	0.70	1.00	1.40	1.90	2.90	4.30	6.00	10.30

Ideale quando gli spessori della plastica sono sottili, perchè i filetti vengono utilizzati completamente. Rispetto alle viti autofilettanti risulta ottima la resistenza allo strappo e la resistenza alle vibrazioni.

*Ideal for thinner plastics because the threads are used completely. Higher resistance to tear and vibration compared to self-tapping screws.*

Ideal für kleinere Kunststoff Materialstärken, da das Gewinde komplett verwendet wird. Bietet auch besseren Halt bei Riss und Vibrationen im Gegensatz zu selbstschneidende Schrauben.

*Idéal pour épaisseur de plastique réduit, puisque le filetage est pleinement exploité. Resistance à l'arrachement et aux vibrations optimale par rapport aux vis autotaraudeuses.*

Ideal para plásticos menos gruesos porque el paso de rosca se utiliza por completo. Mayor resistencia al desgarró y la vibración en comparación con los tornillos autorroscantes.

**\*Disponibile su richiesta/available upon request**

# VITI PER PLASTICA SENZA PUNTA TIPO FXTC+

SCREWS WITH BLUNT TIP FOR PLASTIC FXTC+ TYPE

SCHRAUBEN OHNE SPITZE FÜR KUNSTSTOFF TYP FXTC+

VIS À BOUT PLAT POUR PLASTIQUE TYPE FXTC+

TORNILLOS METALICOS SIN PUNTA PARA FIJAR EN PLASTICO TIPO FXTC+

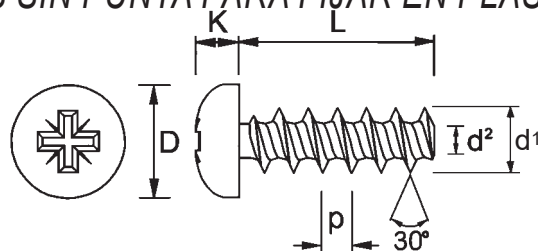

Misura / Size d1	2.2	2.5	3.0	3.5	4.0	4.5*	5.0	5.5*	6.0	7.0
Lunghezza/Length	5 - 10	5 - 12	6 - 20	8 - 25	8 - 30	8 - 30	12 - 35	12 - 40	12 - 45	12 - 50
d2	1.25	1.40	1.66	1.91	2.17	2.53	2.68	3.47	3.19	4.77
p	0.98	1.12	1.34	1.57	1.79	2.04	2.24	2.44	2.69	3.04
Foro / Hole	1.54 - 1.87	1.75 - 2.12	2.10 - 2.55	2.45 - 2.97	2.80 - 3.40	3.15-3.82	3.50 - 4.25	3.85	4.20 - 5.10	4.90 - 5.95
D	3.9	4.4	5.3	6.1	7.0	7.3	8.8	9.3	10.5	12.3
K	1.5	1.7	2.0	2.5	2.7	2.8	3.4	3.5	4.0	4.5
Impronta PZ/PH Recess PZ/PH No.	1	1	1	2	2	2	2	2	3	3

FXTC+			FXTC+			FXTC+			FXTC+		
Filetto Thread Size	Lunghezza Length	Codice Code	Filetto Thread Size	Lunghezza Length	Codice Code	Filetto Thread Size	Lunghezza Length	Codice Code	Filetto Thread Size	Lunghezza Length	Codice Code
ø 2.2	5	13TC+2205ZB	ø 3.5	8	13TC+3508ZB	ø 4.5	8	13TC+4508ZB	ø 6	12	13TC+6012ZB
	6	13TC+2206ZB		10	13TC+3510ZB		10	13TC+4510ZB		14	13TC+6014ZB
	8	13TC+2208ZB		12	13TC+3512ZB		12	13TC+4512ZB		16	13TC+6016ZB
	10	13TC+2210ZB		14	13TC+3514ZB		14	13TC+4514ZB		18	13TC+6018ZB
	ø 2.5	5		13TC+2505ZB	16		13TC+3516ZB	16		13TC+4516ZB	20
6		13TC+2506ZB		18	13TC+3518ZB		18	13TC+4518ZB		25	13TC+6025ZB
8		13TC+2508ZB		20	13TC+3520ZB		20	13TC+4520ZB		30	13TC+6030ZB
10		13TC+2510ZB		25	13TC+3525ZB		25	13TC+4525ZB		35	13TC+6035ZB
12		13TC+2512ZB		ø 4	8		13TC+4008ZB	30		13TC+4530ZB	40
ø 3	6	13TC+3006ZB			10		13TC+4010ZB	ø 5		12	13TC+5012ZB
	8	13TC+3008ZB	12		13TC+4012ZB	14	13TC+5014ZB		ø 7	12	13TC+7012ZB
	10	13TC+3010ZB	14		13TC+4014ZB	16	13TC+5016ZB			14	13TC+7014ZB
	12	13TC+3012ZB	16		13TC+4016ZB	18	13TC+5018ZB			16	13TC+7016ZB
	14	13TC+3014ZB	18		13TC+4018ZB	20	13TC+5020ZB			18	13TC+7018ZB
	16	13TC+3016ZB	20		13TC+4020ZB	25	13TC+5025ZB			20	13TC+7020ZB
	18	13TC+3018ZB	25		13TC+4025ZB	30	13TC+5030ZB			25	13TC+7025ZB
	20	13TC+3020ZB	30		13TC+4030ZB	35	13TC+5035ZB			30	13TC+7030ZB
ø 3.0	6	13TC+3006ZB	ø 5.5		8	13TC+4008ZB	12			13TC+5512ZB	35
	8	13TC+3008ZB		10	13TC+4010ZB	14	13TC+5514ZB			40	13TC+7040ZB
	10	13TC+3010ZB		12	13TC+4012ZB	16	13TC+5516ZB	45		13TC+7045ZB	
	12	13TC+3012ZB		14	13TC+4014ZB	18	13TC+5518ZB	50	13TC+7050ZB		
	14	13TC+3014ZB		16	13TC+4016ZB	20	13TC+5520ZB				
	16	13TC+3016ZB		18	13TC+4018ZB	25	13TC+5525ZB				
	18	13TC+3018ZB		20	13TC+4020ZB	30	13TC+5530ZB				
	20	13TC+3020ZB		25	13TC+4025ZB	35	13TC+5535ZB				
				30	13TC+4030ZB	40	13TC+5540ZB				

\*Disponibile su richiesta/available upon request

**VITI PER PLASTICA SENZA PUNTA TIPO FXTS+**  
**SCREWS WITH BLUNT TIP FOR PLASTIC FXTS+ TYPE**  
**SCHRAUBEN OHNE SPITZE FÜR KUNSTSTOFF TYP FXTS+**  
**VIS À BOUT PLAT POUR PLASTIQUE TYPE FXTS+**  
**TORNILLOS METALICOS SIN PUNTA PARA FIJAR EN PLASTICO TIPO FXTS+**

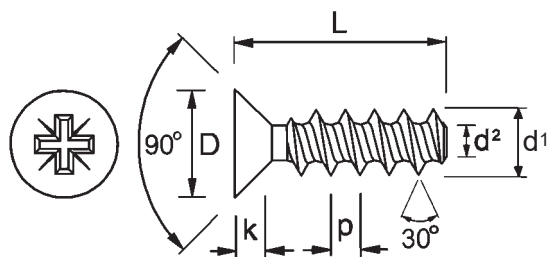

Misura / Size d1	2.2	2.5	3.0	3.5	4.0	5.0	6.0
Lunghezza/Length	5 - 10	5 - 18	6 - 25	8 - 25	10 - 30	10 - 30	12 - 30
d2	1.25	1.40	1.66	1.91	2.17	2.68	3.19
p	0.98	1.12	1.34	1.57	1.79	2.24	2.69
Foro / Hole	1.54 - 1.87	1.75 - 2.12	2.10 - 2.55	2.45 - 2.97	2.80 - 3.40	3.50 - 4.25	4.20 - 5.10
D	3.8	4.7	5.5	7.3	8.4	9.3	11.3
K	1.30	1.75	2.05	2.8	3.25	3.4	3.8
Impronta PZ/PH Recess PZ/PH No.	1	1	1	2	2	2	3

Filetto Thread Size	Lunghezza Length	Codice Code
Ø 2.2	5	13TS+2205ZB
	6	13TS+2206ZB
	8	13TS+2208ZB
	10	13TS+2210ZB
Ø 2.5	5	13TS+2505ZB
	6	13TS+2506ZB
	8	13TS+2508ZB
	10	13TS+2510ZB
	12	13TS+2512ZB
	14	13TS+2514ZB
	16	13TS+2516ZB
	18	13TS+2518ZB
Ø 3	6	13TS+3006ZB
	8	13TS+3008ZB
	10	13TS+3010ZB
	12	13TS+3012ZB
	14	13TS+3014ZB
	16	13TS+3016ZB
	18	13TS+3018ZB
	20	13TS+3020ZB
	25	13TS+3025ZB

Filetto Thread Size	Lunghezza Length	Codice Code
Ø 3.5	8	13TS+3508ZB
	10	13TS+3510ZB
	12	13TS+3512ZB
	14	13TS+3514ZB
	16	13TS+3516ZB
	18	13TS+3518ZB
	20	13TS+3520ZB
	25	13TS+3525ZB
Ø 4	10	13TS+4010ZB
	12	13TS+4012ZB
	14	13TS+4014ZB
	16	13TS+4016ZB
	18	13TS+4018ZB
	20	13TS+4020ZB
	25	13TS+4025ZB
	30	13TS+4030ZB

Filetto Thread Size	Lunghezza Length	Codice Code
Ø 5	10	13TS+5010ZB
	12	13TS+5012ZB
	14	13TS+5014ZB
	16	13TS+5016ZB
	18	13TS+5018ZB
	20	13TS+5020ZB
	25	13TS+5025ZB
	30	13TS+5030ZB
Ø 6	12	13TS+6012ZB
	14	13TS+6014ZB
	16	13TS+6016ZB
	18	13TS+6018ZB
	20	13TS+6020ZB
	25	13TS+6025ZB
	30	13TS+6030ZB

# VITI PER PLASTICA SENZA PUNTA TIPO FXTCF+

SCREWS WITH BLUNT TIP FOR PLASTIC FXTCF+ TYPE

SCHRAUBEN OHNE SPITZE FÜR KUNSTSTOFF TYP FXTCF+

VIS À BOUT PLAT POUR PLASTIQUE TYPE FXTCF+

TORNILLOS METALICOS SIN PUNTA PARA FIJAR EN PLASTICO TIPO FXTCF+

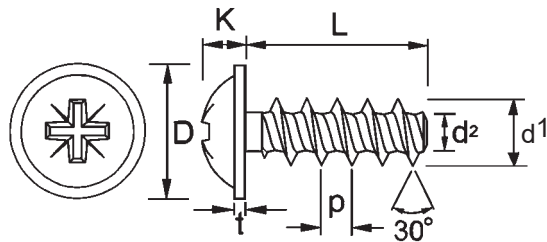

Misura / Size d1	2.2	2.5	3.0	3.5	4.0	4.5*	5.0	5.5*	6.0	7.0
Lunghezza/Length	5 - 10	5 - 12	6 - 20	8 - 25	8 - 30	8 - 30	12 - 30	12 - 40	12 - 40	12 - 50
d2	1.25	1.40	1.66	1.91	2.17	2.53	2.68	3.47	3.19	4.77
p	0.98	1.12	1.34	1.57	1.79	2.04	2.24	2.44	2.69	3.04
Foro / Hole	1.54 - 1.87	1.75 - 2.12	2.10 - 2.55	2.45 - 2.97	2.80 - 3.40	3.15 - 3.82	3.50 - 4.25	3.85 - 4.67	4.20 - 5.10	4.90 - 5.95
D	4.4	5.0	6.0	7.0	8.0	9.3	10.0	11.3	12.0	14.8
K	1.6	1.8	2.1	2.4	2.5	2.7	3.2	3.4	4.0	4.4
t	0.5	0.6	0.7	0.8	0.9	1.0	1.1	1.1	1.3	1.4
Impronta PZ/PH Recess PZ/PH No.	1	1	1	2	2	2	2	2	3	3

 <b>FXTCF+</b>		
Filetto Thread Size	Lunghezza Length	Codice Code
Ø 2.2	5	13TCF+2205ZB
	6	13TCF+2206ZB
	8	13TCF+2208ZB
	10	13TCF+2210ZB
Ø 2.5	5	13TCF+2505ZB
	6	13TCF+2506ZB
	8	13TCF+2508ZB
	10	13TCF+2510ZB
	12	13TCF+2512ZB
Ø 3	6	13TCF+3006ZB
	8	13TCF+3008ZB
	10	13TCF+3010ZB
	12	13TCF+3012ZB
	14	13TCF+3014ZB
	16	13TCF+3016ZB
	18	13TCF+3018ZB
Ø 3.5	20	13TCF+3020ZB
	8	13TCF+3508ZB
	10	13TCF+3510ZB
	12	13TCF+3512ZB
	14	13TCF+3514ZB
	16	13TCF+3516ZB
	18	13TCF+3518ZB
	20	13TCF+3520ZB
25	13TCF+3525ZB	

 <b>FXTCF+</b>		
Filetto Thread Size	Lunghezza Length	Codice Code
Ø 4	8	13TCF+4008ZB
	10	13TCF+4010ZB
	12	13TCF+4012ZB
	14	13TCF+4014ZB
	16	13TCF+4016ZB
	18	13TCF+4018ZB
	20	13TCF+4020ZB
	25	13TCF+4025ZB
	30	13TCF+4030ZB
	Ø 4.5*	8
10		13TCF+4510ZB
12		13TCF+4512ZB
14		13TCF+4514ZB
16		13TCF+4516ZB
18		13TCF+4518ZB
20		13TCF+4520ZB
25		13TCF+4525ZB
30		13TCF+4530ZB
Ø 5		12
	14	13TCF+5014ZB
	16	13TCF+5016ZB
	18	13TCF+5018ZB
	20	13TCF+5020ZB
	25	13TCF+5025ZB
	30	13TCF+5030ZB

 <b>FXTCF+</b>		
Filetto Thread Size	Lunghezza Length	Codice Code
Ø 5.5*	12	13TCF+5512ZB
	14	13TCF+5514ZB
	16	13TCF+5516ZB
	18	13TCF+5518ZB
	20	13TCF+5520ZB
	25	13TCF+5525ZB
	30	13TCF+5530ZB
	35	13TCF+5535ZB
Ø 6	40	13TCF+5540ZB
	12	13TCF+6012ZB
	14	13TCF+6014ZB
	16	13TCF+6016ZB
	18	13TCF+6018ZB
	20	13TCF+6020ZB
	25	13TCF+6025ZB
	30	13TCF+6030ZB
Ø 7	35	13TCF+6035ZB
	40	13TCF+6040ZB
	12	13TCF+7012ZB
	14	13TCF+7014ZB
	16	13TCF+7016ZB
	18	13TCF+7018ZB
	20	13TCF+7020ZB
	25	13TCF+7025ZB
	30	13TCF+7030ZB
	35	13TCF+7035ZB
Ø 7	40	13TCF+7040ZB
	45	13TCF+7045ZB
	50	13TCF+7050ZB

\*Disponibile su richiesta/available upon request

# VITI PER PLASTICA SENZA PUNTA TIPO FXTCTX

SCREWS WITH BLUNT TIP FOR PLASTIC FXTCTX TYPE

SCHRAUBEN OHNE SPITZE FÜR KUNSTSTOFF TYP FXTCTX

VIS À BOUT PLAT POUR PLASTIQUE TYPE FXTCTX

TORNILLOS METALICOS SIN PUNTA PARA FIJAR EN PLASTICO TIPO FXTCTX

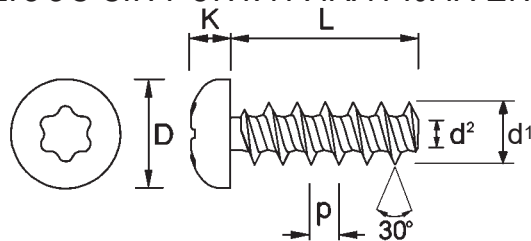

Misura / Size d1	1.8	2.2	2.5	3.0	3.5	4.0	5.0	6.0
Lunghezza/Length	5 - 12	5 - 10	5 - 12	6 - 20	8 - 25	8 - 30	12 - 35	12 - 45
d2	1.04	1.25	1.40	1.66	1.91	2.17	2.68	3.19
p	0.80	0.98	1.12	1.34	1.57	1.79	2.24	2.69
Foro / Hole	1.26 - 1.53	1.54 - 1.87	1.75 - 2.12	2.10 - 2.55	2.45 - 2.97	2.80 - 3.40	3.50 - 4.25	4.20 - 5.10
D	3.6	4.0	4.2	5.6	6.9	7.5	8.2	10.8
K	1.3	1.5	1.6	2.1	2.3	2.6	2.9	3.8
Impronta PZ/PH Recess PZ/PH No.	T 6	T 6	T 8	T 10	T 10	T 20	T 20	T 25

FXTCTX		
Filetto Thread Size	Lunghezza Length	Codice Code
Ø 1.8	5	13TCTX1805ZB
	6	13TCTX1806ZB
	8	13TCTX1808ZB
	10	13TCTX1810ZB
	12	13TCTX1812ZB
	Ø 2.2	5
6		13TCTX2206ZB
8		13TCTX2208ZB
10		13TCTX2210ZB
Ø 2.5	5	13TCTX2505ZB
	6	13TCTX2506ZB
	8	13TCTX2508ZB
	10	13TCTX2510ZB
	12	13TCTX2512ZB

FXTCTX		
Filetto Thread Size	Lunghezza Length	Codice Code
Ø 3	6	13TCTX3006ZB
	8	13TCTX3008ZB
	10	13TCTX3010ZB
	12	13TCTX3012ZB
	14	13TCTX3014ZB
	16	13TCTX3016ZB
	18	13TCTX3018ZB
	20	13TCTX3020ZB
Ø 3.5	8	13TCTX3508ZB
	10	13TCTX3510ZB
	12	13TCTX3512ZB
	14	13TCTX3514ZB
	16	13TCTX3516ZB
	18	13TCTX3518ZB
	20	13TCTX3520ZB
	25	13TCTX3525ZB

FXTCTX		
Filetto Thread Size	Lunghezza Length	Codice Code
Ø 4	8	13TCTX4008ZB
	10	13TCTX4010ZB
	12	13TCTX4012ZB
	14	13TCTX4014ZB
	16	13TCTX4016ZB
	18	13TCTX4018ZB
	20	13TCTX4020ZB
	25	13TCTX4025ZB
	30	13TCTX4030ZB
	Ø 5	12
14		13TCTX5014ZB
16		13TCTX5016ZB
18		13TCTX5018ZB
20		13TCTX5020ZB
25		13TCTX5025ZB
30		13TCTX5030ZB
Ø 6	35	13TCTX5035ZB
	12	13TCTX6012ZB
	14	13TCTX6014ZB
	16	13TCTX6016ZB
	18	13TCTX6018ZB
	20	13TCTX6020ZB
	25	13TCTX6025ZB
	30	13TCTX6030ZB
	35	13TCTX6030ZB
	40	13TCTX6040ZB
	45	13TCTX6045ZB

# VITI PER PLASTICA SENZA PUNTA TIPO FXTCFTX

SCREWS WITH BLUNT TIP FOR PLASTIC FXTCFTX TYPE

SCHRAUBEN OHNE SPITZE FÜR KUNSTSTOFF TYP FXTCFTX

VIS À BOUT PLAT POUR PLASTIQUE TYPE FXTCFTX

TORNILLOS METALICOS SIN PUNTA PARA FIJAR EN PLASTICO TIPO FXTCFTX

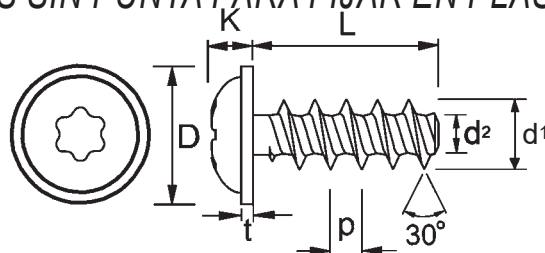

Misura / Size d1	2.2	2.5	3.0	3.5	4.0	5.0	6.0
Lunghezza/Length	4 - 10	5 - 10	6 - 25	8 - 25	8 - 30	8 - 30	12 - 30
d2	1.25	1.40	1.66	1.91	2.17	2.68	3.19
p	0.98	1.12	1.34	1.57	1.79	2.24	2.69
Foro / Hole	1.54 - 1.87	1.75 - 2.12	2.10 - 2.55	2.45 - 2.97	2.80 - 3.40	3.50 - 4.25	4.20 - 5.10
D	4.5	5.0	6.0	7.0	8.0	10.0	12.0
K	1.4	1.5	2.1	2.4	2.6	3.3	3.6
t	0.5	0.5	0.6	0.7	0.8	1.0	1.2
Impronta PZ/PH Recess PZ/PH No.	T 6	T 6	T 10	T 10	T 20	T 20	T 25

Filetto Thread Size	Lunghezza Length	Codice Code
Ø 2.2	4	13TCFTX2204ZB
	6	13TCFTX2206ZB
	8	13TCFTX2208ZB
	10	13TCFTX2210ZB
Ø 2.5	5	13TCFTX2505ZB
	6	13TCFTX2506ZB
	8	13TCFTX2508ZB
	10	13TCFTX2510ZB
Ø 3	6	13TCFTX3006ZB
	8	13TCFTX3008ZB
	10	13TCFTX3010ZB
	12	13TCFTX3012ZB
	14	13TCFTX3014ZB
	16	13TCFTX3016ZB
	18	13TCFTX3018ZB
	20	13TCFTX3020ZB
25	13TCFTX3025ZB	

Filetto Thread Size	Lunghezza Length	Codice Code
Ø 3.5	8	13TCFTX3508ZB
	10	13TCFTX3510ZB
	12	13TCFTX3512ZB
	14	13TCFTX3514ZB
	16	13TCFTX3516ZB
	18	13TCFTX3518ZB
	20	13TCFTX3520ZB
Ø 4	25	13TCFTX3525ZB
	8	13TCFTX4008ZB
	10	13TCFTX4010ZB
	12	13TCFTX4012ZB
	14	13TCFTX4014ZB
	16	13TCFTX4016ZB
	18	13TCFTX4018ZB
	20	13TCFTX4020ZB
	25	13TCFTX4025ZB
	30	13TCFTX4030ZB

Filetto Thread Size	Lunghezza Length	Codice Code
Ø 5	8	13TCFTX5008ZB
	10	13TCFTX5010ZB
	12	13TCFTX5012ZB
	14	13TCFTX5014ZB
	16	13TCFTX5016ZB
	18	13TCFTX5018ZB
	20	13TCFTX5020ZB
Ø 6	25	13TCFTX5025ZB
	30	13TCFTX5030ZB
	12	13TCFTX6012ZB
	14	13TCFTX6014ZB
	16	13TCFTX6016ZB
	18	13TCFTX6018ZB
	20	13TCFTX6020ZB
	25	13TCFTX6025ZB
	30	13TCFTX6030ZB

A RICHIESTA / ON DEMAND

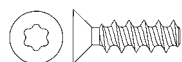

FXTSTX

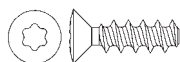

FXTSCTX



FXTE



FXFEF



# VITI PER PLASTICA CON PUNTA TIPO DF - INFORMAZIONI TECNICHE

SCREWS WITH SHARP TIP FOR PLASTIC DF TYPE - TECHNICAL INFORMATION

SCHRAUBEN MIT SPITZE FÜR KUNSTSTOFF DF - TECHNISCHE INFORMATIONEN

VIS À BOUT POINTU POUR PLASTIQUE DF - DONNÉES TECHNIQUES

TORNILLOS METALICOS CON PUNTA PARA FIJAR EN PLASTICO DF - INFORMACION TECNICA

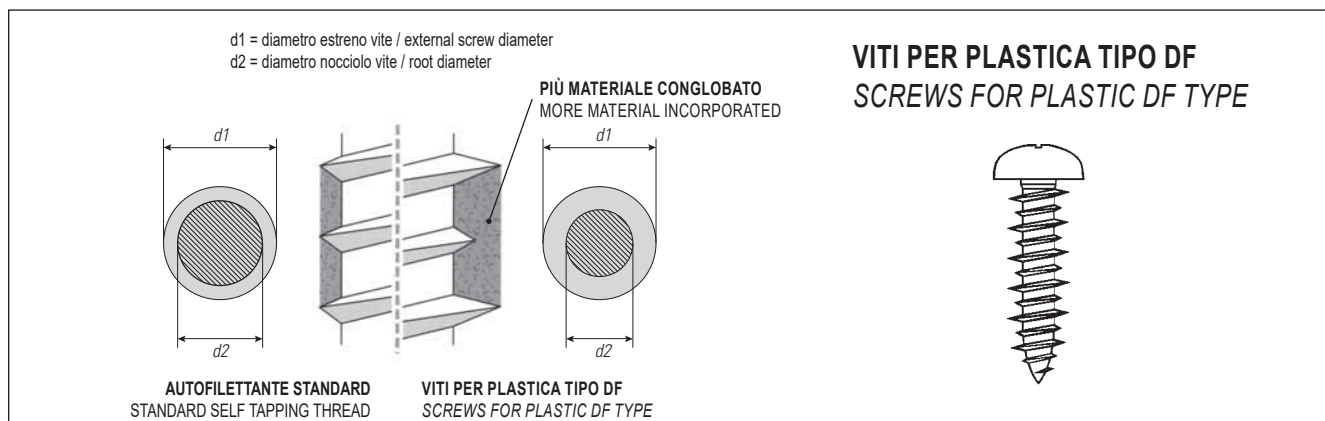

Diametro vite nominale (d1) Nominal screw diameter (d1)	3.0	3.5	4.0	4.5	5.0	5.5	6.0	7.0
Foro Hole (d1x0,7)-(d1x0,9)	2.10 - 2.70	2.45 - 3.15	2.80 - 3.60	3.15 - 4.05	3.50 - 4.50	3.85 - 4.95	4.20 - 5.40	4.90 - 6.30
Coppia di rottura (Nm) Breaking Torque (Nm)	1.00	1.45	2.15	2.85	4.35	6.55	9.15	15.60
Coppia di chiusura (Nm) Tightening torque (Nm)	0.70	1.00	1.40	1.90	2.90	4.30	6.00	10.30

Grazie alla punta l'avvitabilità è due volte più rapida. Rispetto alle viti autofilettanti risulta ottima la resistenza allo strappo e la resistenza alle vibrazioni. Ideale quando va svitata e avvitata più volte, il rischio di spanamento si riduce rispetto alle viti tipo FX (pag. 30) e alle viti autofilettanti.

*Thanks to the tip it screws twice as fast. Higher resistance to tear and vibration compared to self-tapping screws. Ideal when screwed and unscrewed several times, the risk of stripping is reduced compared to FX TYPE screws (page 30) and to self-tapping screws.*

Bietet auch besseren Halt bei Riss und Vibrationen im Gegensatz zu selbstschneidende Schrauben. Ideal für mehrmalige Auf- und Ausschraubungen. Das Abisolierungs Risiko ist im Gegensatz zu Schrauben Typ FX (Seite 30) und zu selbstschneidende Schrauben geringer.

*Rapidité d'installation, grâce à la pointe. Résistance à l'arrachement et aux vibrations optimale par rapport aux vis autotaraudeuses. Idéal pour plusieurs vissages et dévissages, avec un faible risque de détérioration du plastique.*

Gracias a la punta se atornilla el doble de rápido. Mayor resistencia al desgarró y la vibración en comparación con los tornillos autorroscantes. Ideal para atornillar y desatornillar múltiples veces, con menor riesgo de desgaste que los tornillos tipo FX (página 30) y los tornillos autorroscantes.

# VITI PER PLASTICA CON PUNTA TIPO DFTC+

SCREWS WITH SHARP TIP FOR PLASTIC DF TYPE

SCHRAUBEN MIT SPITZE FÜR KUNSTSTOFF TYP DF

VIS À BOUT POINTU POUR PLASTIQUE TYPE DF

TORNILLOS METALICOS CON PUNTA PARA FIJAR EN PLASTICO TIPO DF

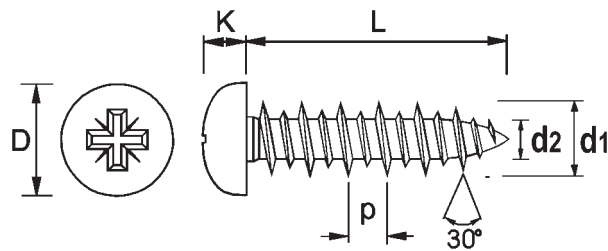

Misura / Size d1	3.0	3.5	4.0	4.5	5.0	5.5	6.0	7.0
Lunghezza/Length	8 - 20	8 - 25	8 - 30	8 - 30	10 - 35	10 - 40	10 - 45	10 - 50
d2	1.85	2.0	2.30	2.50	2.85	3.35	3.75	4.75
p	2.10	2.50	2.70	2.80	3.0	3.0	3.10	3.50
Foro / Hole	2.10 - 2.70	2.45 - 3.15	2.80 - 3.60	3.15 - 4.05	3.50 - 4.50	3.85 - 4.95	4.20 - 5.40	4.90 - 6.30
D	4.60 - 4.90	5.30 - 5.60	6.54 - 6.90	7.14 - 7.50	7.84 - 8.20	9.14 - 9.50	10.37 - 10.80	12.07 - 12.50
K	1.75 - 2.0	1.95 - 2.20	2.35 - 2.60	2.55 - 2.80	2.75 - 3.05	3.25 - 3.55	3.65 - 3.95	4.25 - 4.55
Impronta PZ/PH Recess PZ/PH No.	1	1	2	2	2	2	3	3

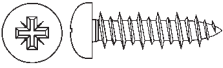
 <b>DFTC+</b>		
Filetto Thread Size	Lunghezza Length	Codice Code
ø 3	8	13DFTC+3008ZB
	10	13DFTC+3010ZB
	12	13DFTC+3012ZB
	14	13DFTC+3014ZB
	16	13DFTC+3016ZB
	18	13DFTC+3018ZB
	20	13DFTC+3020ZB
	ø 3.5	8
10		13DFTC+3510ZB
12		13DFTC+3512ZB
14		13DFTC+3514ZB
16		13DFTC+3516ZB
18		13DFTC+3518ZB
20		13DFTC+3520ZB
25		13DFTC+3525ZB
ø 4	8	13DFTC+4008ZB
	10	13DFTC+4010ZB
	12	13DFTC+4012ZB
	14	13DFTC+4014ZB
	16	13DFTC+4016ZB
	18	13DFTC+4018ZB
	20	13DFTC+4020ZB
	25	13DFTC+4025ZB
	30	13DFTC+4030ZB

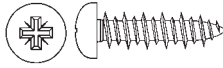
 <b>DFTC+</b>		
Filetto Thread Size	Lunghezza Length	Codice Code
ø 4.5	8	13DFTC+4508ZB
	10	13DFTC+4510ZB
	12	13DFTC+4512ZB
	14	13DFTC+4514ZB
	16	13DFTC+4516ZB
	18	13DFTC+4518ZB
	20	13DFTC+4520ZB
	25	13DFTC+4525ZB
	30	13DFTC+4530ZB
	ø 5	10
12		13DFTC+5012ZB
14		13DFTC+5014ZB
16		13DFTC+5016ZB
18		13DFTC+5018ZB
20		13DFTC+5020ZB
25		13DFTC+5025ZB
30		13DFTC+5030ZB
35		13DFTC+5035ZB
ø 5.5		10
	12	13DFTC+5512ZB
	14	13DFTC+5514ZB
	16	13DFTC+5516ZB
	18	13DFTC+5518ZB
	20	13DFTC+5520ZB
	25	13DFTC+5525ZB
	30	13DFTC+5530ZB
	35	13DFTC+5535ZB
	40	13DFTC+5540ZB

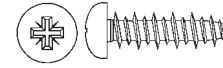
 <b>DFTC+</b>		
Filetto Thread Size	Lunghezza Length	Codice Code
ø 6	10	13DFTC+6010ZB
	12	13DFTC+6012ZB
	14	13DFTC+6014ZB
	16	13DFTC+6016ZB
	18	13DFTC+6018ZB
	20	13DFTC+6020ZB
	25	13DFTC+6025ZB
	30	13DFTC+6030ZB
	35	13DFTC+6035ZB
	40	13DFTC+6040ZB
ø 7	45	13DFTC+6045ZB
	10	13DFTC+7010ZB
	12	13DFTC+7012ZB
	14	13DFTC+7014ZB
	16	13DFTC+7016ZB
	18	13DFTC+7018ZB
	20	13DFTC+7020ZB
	25	13DFTC+7025ZB
	30	13DFTC+7030ZB
	35	13DFTC+7035ZB
ø 7	40	13DFTC+7040ZB
	45	13DFTC+7045ZB
	50	13DFTC+7050ZB



# VITI PER PLASTICA CON PUNTA TIPO DFTCF+

SCREWS WITH SHARP TIP FOR PLASTIC DFTCF+ TYPE  
SCHRAUBEN MIT SPITZE FÜR KUNSTSTOFF TYP DFTCF+  
VIS À BOUT POINTU POUR PLASTIQUE TYPE DFTCF+  
TORNILLOS METALICOS CON PUNTA PARA FIJAR EN PLASTICO TIPO DFTCF+

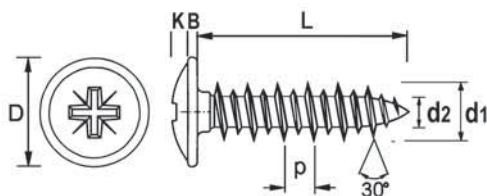

Misura / Size d1	3.0	3.5	4.0	4.5	5.0	5.5	6.0	7.0
Lunghezza/Length	8 - 20	8 - 25	8 - 30	8 - 30	10 - 35	10 - 40	10 - 45	10 - 50
d2	1.85	2.0	2.30	2.50	2.85	3.35	3.75	4.75
p	2.10	2.50	2.70	2.80	3.0	3.0	3.10	3.50
Foro / Hole	2.10 - 2.70	2.45 - 3.15	2.80 - 3.60	3.15 - 4.05	3.50 - 4.50	3.85 - 4.95	4.20 - 5.40	4.90 - 6.30
D	6.24 - 6.60	7.04 - 7.40	8.44 - 8.80	9.14 - 9.50	9.87 - 10.30	11.07 - 11.50	12.57 - 13.0	14.57 - 15.0
K + B	1.75 - 2.0	1.95 - 2.20	2.35 - 2.60	2.55 - 2.80	2.75 - 3.05	3.25 - 3.55	3.65 - 3.95	4.25 - 4.55
B	0.47 - 0.72	0.57 - 0.82	0.67 - 0.92	0.77 - 1.02	0.87 - 1.12	0.97 - 1.22	1.07 - 1.32	1.27 - 1.52
Impronta PZ/PH Recess PZ/PH No.	1	1	2	2	2	2	3	3

DFTCF+		
Filetto Thread Size	Lunghezza Length	Codice Code
Ø 3	8	13DFTCF+3008ZB
	10	13DFTCF+3010ZB
	12	13DFTCF+3012ZB
	14	13DFTCF+3014ZB
	16	13DFTCF+3016ZB
	18	13DFTCF+3018ZB
	20	13DFTCF+3020ZB
Ø 3.5	8	13DFTCF+3508ZB
	10	13DFTCF+3510ZB
	12	13DFTCF+3512ZB
	14	13DFTCF+3514ZB
	16	13DFTCF+3516ZB
	18	13DFTCF+3518ZB
	20	13DFTCF+3520ZB
Ø 4	8	13DFTCF+4008ZB
	10	13DFTCF+4010ZB
	12	13DFTCF+4012ZB
	14	13DFTCF+4014ZB
	16	13DFTCF+4016ZB
	18	13DFTCF+4018ZB
	20	13DFTCF+4020ZB
Ø 4	25	13DFTCF+4025ZB
	30	13DFTCF+4030ZB

DFTCF+		
Filetto Thread Size	Lunghezza Length	Codice Code
Ø 4.5	8	13DFTCF+4508ZB
	10	13DFTCF+4510ZB
	12	13DFTCF+4512ZB
	14	13DFTCF+4514ZB
	16	13DFTCF+4516ZB
	18	13DFTCF+4518ZB
	20	13DFTCF+4520ZB
	25	13DFTCF+4525ZB
	30	13DFTCF+4530ZB
	Ø 5	10
12		13DFTCF+5012ZB
14		13DFTCF+5014ZB
16		13DFTCF+5016ZB
18		13DFTCF+5018ZB
20		13DFTCF+5020ZB
25		13DFTCF+5025ZB
30		13DFTCF+5030ZB
35		13DFTCF+5035ZB
Ø 5.5		10
	12	13DFTCF+5512ZB
	14	13DFTCF+5514ZB
	16	13DFTCF+5516ZB
	18	13DFTCF+5518ZB
	20	13DFTCF+5520ZB
	25	13DFTCF+5525ZB
	30	13DFTCF+5530ZB
	35	13DFTCF+5535ZB
	40	13DFTCF+5540ZB

DFTCF+			
Filetto Thread Size	Lunghezza Length	Codice Code	
Ø 6	10	13DFTCF+6010ZB	
	12	13DFTCF+6012ZB	
	14	13DFTCF+6014ZB	
	16	13DFTCF+6016ZB	
	18	13DFTCF+6018ZB	
	20	13DFTCF+6020ZB	
	25	13DFTCF+6025ZB	
	30	13DFTCF+6030ZB	
	35	13DFTCF+6035ZB	
	40	13DFTCF+6040ZB	
Ø 6	45	13DFTCF+6045ZB	
	Ø 7	10	13DFTCF+7010ZB
		12	13DFTCF+7012ZB
		14	13DFTCF+7014ZB
		16	13DFTCF+7016ZB
		18	13DFTCF+7018ZB
		20	13DFTCF+7020ZB
		25	13DFTCF+7025ZB
		30	13DFTCF+7030ZB
		35	13DFTCF+7035ZB
40		13DFTCF+7040ZB	
Ø 7	45	13DFTCF+7045ZB	
	50	13DFTCF+7050ZB	

# VITI PER PLASTICA CON PUNTA TIPO DFTEF

SCREWS WITH SHARP TIP FOR PLASTIC DFTEF TYPE

SCHRAUBEN MIT SPITZE FÜR KUNSTSTOFF TYP DFTEF

VIS À BOUT POINTU POUR PLASTIQUE TYPE DFTEF

TORNILLOS METALICOS CON PUNTA PARA FIJAR EN PLASTICO TIPO DFTEF

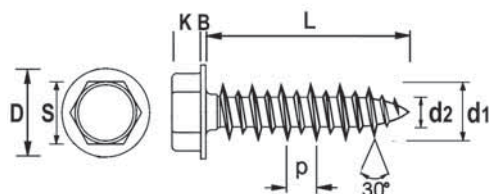

Misura / Size d1	3.0	3.5	4.0	4.5	5.0	5.5	6.0	7.0
Lunghezza/Length	-	8 - 25	8 - 30	8 - 30	10 - 35	10 - 40	10 - 45	10 - 50
d2	-	2.0	2.30	2.50	2.85	3.35	3.75	4.75
p	-	2.50	2.70	2.80	3.0	3.0	3.10	3.50
Foro / Hole	-	2.45 - 3.15	2.80 - 3.60	3.15 - 4.05	3.50 - 4.50	3.85 - 4.95	4.20 - 5.40	4.90 - 6.30
D	-	6.02 - 6.50	6.61 - 7.21	8.46 - 9.18	9.01 - 9.73	9.85 - 10.61	10.20 - 11.08	12.80 - 13.66
S	-	4.82 - 5.0	5.32 - 5.50	6.78 - 7.0	6.78 - 7.0	7.78 - 8.0	7.78 - 8.0	9.78 - 10.0
K	-	1.62 - 1.87	2.42 - 2.67	2.42 - 2.67	2.92 - 3.17	3.12 - 3.42	4.15 - 4.45	4.95 - 5.25
B	-	0.28 - 0.50	0.32 - 0.54	0.47 - 0.80	0.48 - 0.78	0.48 - 0.78	0.55 - 0.99	0.79 - 1.33
Impronta PZ/PH Recess PZ/PH No.	-	1	2	2	2	2	3	3

DFTEF		
Filetto Thread Size	Lunghezza Length	Codice Code
Ø 3.5	8	13DFTEF3508ZB
	10	13DFTEF3510ZB
	12	13DFTEF3512ZB
	14	13DFTEF3514ZB
	16	13DFTEF3516ZB
	18	13DFTEF3518ZB
	20	13DFTEF3520ZB
	25	13DFTEF3525ZB
Ø 4	8	13DFTEF4008ZB
	10	13DFTEF4010ZB
	12	13DFTEF4012ZB
	14	13DFTEF4014ZB
	16	13DFTEF4016ZB
	18	13DFTEF4018ZB
	20	13DFTEF4020ZB
	25	13DFTEF4025ZB
	30	13DFTEF4030ZB

DFTEF		
Filetto Thread Size	Lunghezza Length	Codice Code
Ø 4.5	8	13DFTEF4508ZB
	10	13DFTEF4510ZB
	12	13DFTEF4512ZB
	14	13DFTEF4514ZB
	16	13DFTEF4516ZB
	18	13DFTEF4518ZB
	20	13DFTEF4520ZB
	25	13DFTEF4525ZB
	30	13DFTEF4530ZB
Ø 5	10	13DFTEF5010ZB
	12	13DFTEF5012ZB
	14	13DFTEF5014ZB
	16	13DFTEF5016ZB
	18	13DFTEF5018ZB
	20	13DFTEF5020ZB
	25	13DFTEF5025ZB
	30	13DFTEF5030ZB
	35	13DFTEF5035ZB

DFTEF		
Filetto Thread Size	Lunghezza Length	Codice Code
Ø 5.5	10	13DFTEF5510ZB
	12	13DFTEF5512ZB
	14	13DFTEF5514ZB
	16	13DFTEF5516ZB
	18	13DFTEF5518ZB
	20	13DFTEF5520ZB
	25	13DFTEF5525ZB
	30	13DFTEF5530ZB
	35	13DFTEF5535ZB
	40	13DFTEF5540ZB
Ø 6	10	13DFTEF6010ZB
	12	13DFTEF6012ZB
	14	13DFTEF6014ZB
	16	13DFTEF6016ZB
	18	13DFTEF6018ZB
	20	13DFTEF6020ZB
	25	13DFTEF6025ZB
	30	13DFTEF6030ZB
	35	13DFTEF6035ZB
	40	13DFTEF6040ZB
Ø 7	10	13DFTEF7010ZB
	12	13DFTEF7012ZB
	14	13DFTEF7014ZB
	16	13DFTEF7016ZB
	18	13DFTEF7018ZB
	20	13DFTEF7020ZB
	25	13DFTEF7025ZB
	30	13DFTEF7030ZB
	35	13DFTEF7035ZB
	40	13DFTEF7040ZB
45	13DFTEF7045ZB	
50	13DFTEF7050ZB	

**VITI PER PLASTICA CON PUNTA TIPO DFTS+**

SCREWS WITH SHARP TIP FOR PLASTIC DFTS+ TYPE

SCHRAUBEN MIT SPITZE FÜR KUNSTSTOFF TYP DFTS+

VIS À BOUT POINTU POUR PLASTIQUE TYPE DFTS+

TORNILLOS METALICOS CON PUNTA PARA FIJAR EN PLASTICO TIPO DFTS+

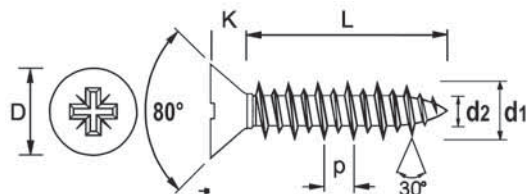

Misura / Size d1	3.0	3.5	4.0	4.5	5.0	5.5	6.0	7.0
Lunghezza/Length	8 - 20	8 - 25	8 - 30	8 - 30	10 - 35	10 - 40	10 - 45	10 - 50
d2	1.85	2.0	2.30	2.50	2.85	3.35	3.75	4.75
p	2.10	2.50	2.70	2.80	3.0	3.0	3.10	3.50
Foro / Hole	2.10 - 2.70	2.45 - 3.15	2.80 - 3.60	3.15 - 4.05	3.50 - 4.50	3.85 - 4.95	4.20 - 5.40	4.90 - 6.30
D	4.60 - 4.90	5.20 - 5.50	6.44 - 6.80	7.14 - 7.50	7.74 - 8.10	9.14 - 9.50	10.37 - 10.80	11.97 - 12.40
K	1.5	1.7	2.1	2.3	2.5	3.0	3.4	3.8
Impronta PZ/PH Recess PZ/PH No.	1	1	2	2	2	2	3	3

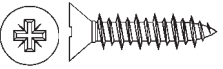
 <b>DFTS+</b>		
Filetto Thread Size	Lunghezza Length	Codice Code
Ø 3	8	13DFTS+3008ZB
	10	13DFTS+3010ZB
	12	13DFTS+3012ZB
	14	13DFTS+3014ZB
	16	13DFTS+3016ZB
	18	13DFTS+3018ZB
	20	13DFTS+3020ZB
	Ø 3.5	8
10		13DFTS+3510ZB
12		13DFTS+3512ZB
14		13DFTS+3514ZB
16		13DFTS+3516ZB
18		13DFTS+3518ZB
20		13DFTS+3520ZB
25		13DFTS+3525ZB
Ø 4	8	13DFTS+4008ZB
	10	13DFTS+4010ZB
	12	13DFTS+4012ZB
	14	13DFTS+4014ZB
	16	13DFTS+4016ZB
	18	13DFTS+4018ZB
	20	13DFTS+4020ZB
	25	13DFTS+4025ZB
	30	13DFTS+4030ZB

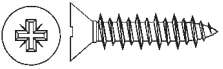
 <b>DFTS+</b>		
Filetto Thread Size	Lunghezza Length	Codice Code
Ø 4.5	8	13DFTS+4508ZB
	10	13DFTS+4510ZB
	12	13DFTS+4512ZB
	14	13DFTS+4514ZB
	16	13DFTS+4516ZB
	18	13DFTS+4518ZB
	20	13DFTS+4520ZB
	25	13DFTS+4525ZB
Ø 5	10	13DFTS+5010ZB
	12	13DFTS+5012ZB
	14	13DFTS+5014ZB
	16	13DFTS+5016ZB
	18	13DFTS+5018ZB
	20	13DFTS+5020ZB
	25	13DFTS+5025ZB
	30	13DFTS+5030ZB
	35	13DFTS+5035ZB

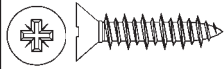
 <b>DFTS+</b>		
Filetto Thread Size	Lunghezza Length	Codice Code
Ø 5.5	10	13DFTS+5510ZB
	12	13DFTS+5512ZB
	14	13DFTS+5514ZB
	16	13DFTS+5516ZB
	18	13DFTS+5518ZB
	20	13DFTS+5520ZB
	25	13DFTS+5525ZB
	30	13DFTS+5530ZB
	35	13DFTS+5535ZB
	40	13DFTS+5540ZB
Ø 6	10	13DFTS+6010ZB
	12	13DFTS+6012ZB
	14	13DFTS+6014ZB
	16	13DFTS+6016ZB
	18	13DFTS+6018ZB
	20	13DFTS+6020ZB
	25	13DFTS+6025ZB
	30	13DFTS+6030ZB
	35	13DFTS+6035ZB
	45	13DFTS+6045ZB
Ø 7	10	13DFTS+7010ZB
	12	13DFTS+7012ZB
	14	13DFTS+7014ZB
	16	13DFTS+7016ZB
	18	13DFTS+7018ZB
	20	13DFTS+7020ZB
	25	13DFTS+7025ZB
	30	13DFTS+7030ZB
	35	13DFTS+7035ZB
	50	13DFTS+7050ZB

# VITI PER PLASTICA CON PUNTA TIPO DFTSC+

SCREWS WITH SHARP TIP FOR PLASTIC DFTSC+ TYPE

SCHRAUBEN MIT SPITZE FÜR KUNSTSTOFF TYP DFTSC+

VIS À BOUT POINTU POUR PLASTIQUE TYPE DFTSC+

TORNILLOS METALICOS CON PUNTA PARA FIJAR EN PLASTICO TIPO DFTSC+

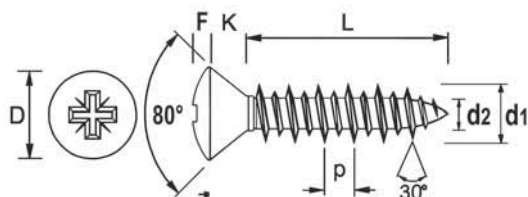

Misura / Size d1	3.0	3.5	4.0	4.5	5.0	5.5	6.0	7.0
Lunghezza/Length	8 - 20	8 - 25	8 - 30	8 - 30	10 - 35	10 - 40	10 - 45	10 - 50
d2	1.85	2.0	2.30	2.50	2.85	3.35	3.75	4.75
p	2.10	2.50	2.70	2.80	3.0	3.0	3.10	3.50
Foro / Hole	2.10 - 2.70	2.45 - 3.15	2.80 - 3.60	3.15 - 4.05	3.50 - 4.50	3.85 - 4.95	4.20 - 5.40	4.90 - 6.30
D	4.60 - 4.90	5.20 - 5.50	6.44 - 6.80	7.14 - 7.50	7.74 - 8.10	9.14 - 9.50	10.37 - 10.80	11.97 - 12.40
K	1.5	1.7	2.1	2.3	2.5	3.0	3.4	3.8
F	0.6	0.9	1.2	1.3	1.4	1.5	1.7	2.0
Impronta PZ/PH Recess PZ/PH No.	1	1	2	2	2	2	3	3

DFTSC+		
Filetto Thread Size	Lunghezza Length	Codice Code
Ø 3	8	13DFTSC+3008ZB
	10	13DFTSC+3010ZB
	12	13DFTSC+3012ZB
	14	13DFTSC+3014ZB
	16	13DFTSC+3016ZB
	18	13DFTSC+3018ZB
	20	13DFTSC+3020ZB
Ø 3.5	8	13DFTSC+3508ZB
	10	13DFTSC+3510ZB
	12	13DFTSC+3512ZB
	14	13DFTSC+3514ZB
	16	13DFTSC+3516ZB
	18	13DFTSC+3518ZB
	20	13DFTSC+3520ZB
Ø 4	8	13DFTSC+4008ZB
	10	13DFTSC+4010ZB
	12	13DFTSC+4012ZB
	14	13DFTSC+4014ZB
	16	13DFTSC+4016ZB

DFTSC+		
Filetto Thread Size	Lunghezza Length	Codice Code
Ø 4.5	8	13DFTSC+4508ZB
	10	13DFTSC+4510ZB
	12	13DFTSC+4512ZB
	14	13DFTSC+4514ZB
	16	13DFTSC+4516ZB
	18	13DFTSC+4518ZB
	20	13DFTSC+4520ZB
Ø 5	10	13DFTSC+5010ZB
	12	13DFTSC+5012ZB
	14	13DFTSC+5014ZB
	16	13DFTSC+5016ZB
	18	13DFTSC+5018ZB

DFTSC+		
Filetto Thread Size	Lunghezza Length	Codice Code
Ø 5.5	10	13DFTSC+5510ZB
	12	13DFTSC+5512ZB
	14	13DFTSC+5514ZB
	16	13DFTSC+5516ZB
	18	13DFTSC+5518ZB
	20	13DFTSC+5520ZB
	25	13DFTSC+5525ZB
	30	13DFTSC+5530ZB
	35	13DFTSC+5535ZB
	40	13DFTSC+5540ZB
Ø 6	10	13DFTSC+6010ZB
	12	13DFTSC+6012ZB
	14	13DFTSC+6014ZB
	16	13DFTSC+6016ZB
	18	13DFTSC+6018ZB
	20	13DFTSC+6020ZB
	25	13DFTSC+6025ZB
	30	13DFTSC+6030ZB
	35	13DFTSC+6035ZB
	40	13DFTSC+6040ZB
Ø 7	10	13DFTSC+7010ZB
	12	13DFTSC+7012ZB
	14	13DFTSC+7014ZB
	16	13DFTSC+7016ZB
	18	13DFTSC+7018ZB
	20	13DFTSC+7020ZB
	25	13DFTSC+7025ZB
	30	13DFTSC+7030ZB
	35	13DFTSC+7035ZB
	40	13DFTSC+7040ZB